

WIGGINS Non-Pressurized Fast Fuel Systems

Work Faster, Cleaner, Safer

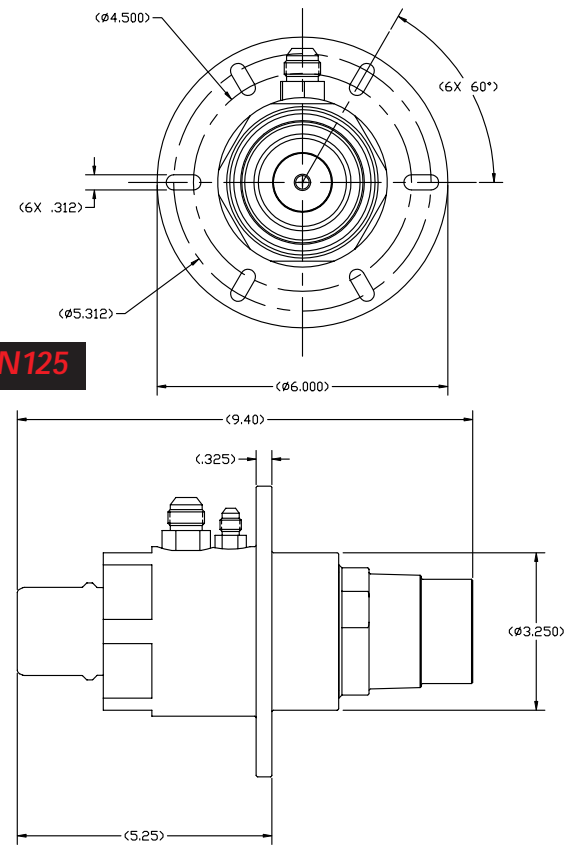

JN125

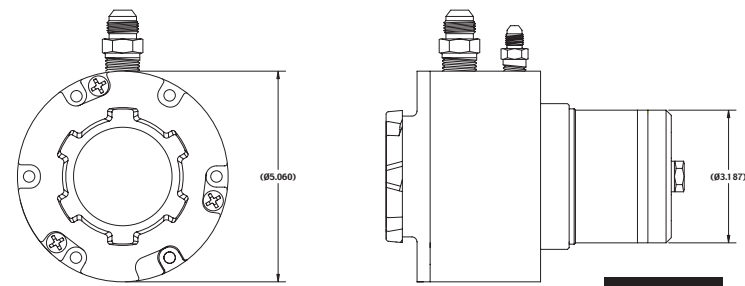

VR 300

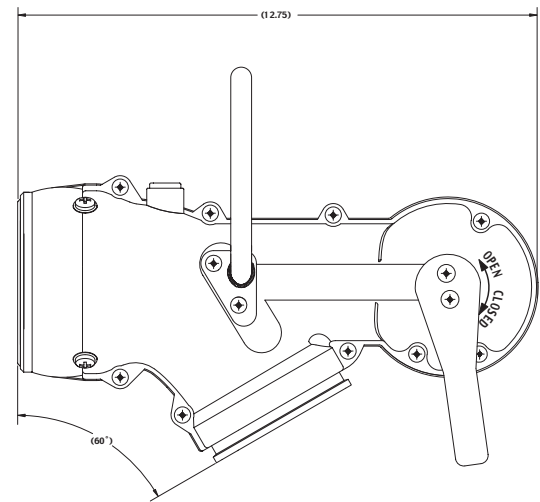

JN125 Specification

Rated Flow:	45 to 135 GPM
Operating Pressure:	60 PSIG
Pressure Drop:	11 PSID @ 100 GPM
Disconnect Spillage:	4 cc
Housing Material:	Aluminum
Weight:	4.25 LBS

VR300 Specification

Rated Flow:	10 to 300 GPM
Operating Pressure:	25 to 125 PSIG
Pressure Drop:	7 PSID @ 200 GPM 18 PSID @ 300 GPM
Connect/Disconnect Rotation:	30 Degrees
Disconnect Spillage:	3 cc, Max.
Housing Material:	Aluminum
Weight:	9 LBS

For more information on the fast fuel systems, and authorized Wiggins Service System Distributors, or to see what is new, please log onto our web-site www.adelwiggins.com



Wiggins Service Systems
5000 Triggs Street, Los Angeles, CA 90022
323.269.9181 ■ Fax: 323.269.3759
www.adelwiggins.com

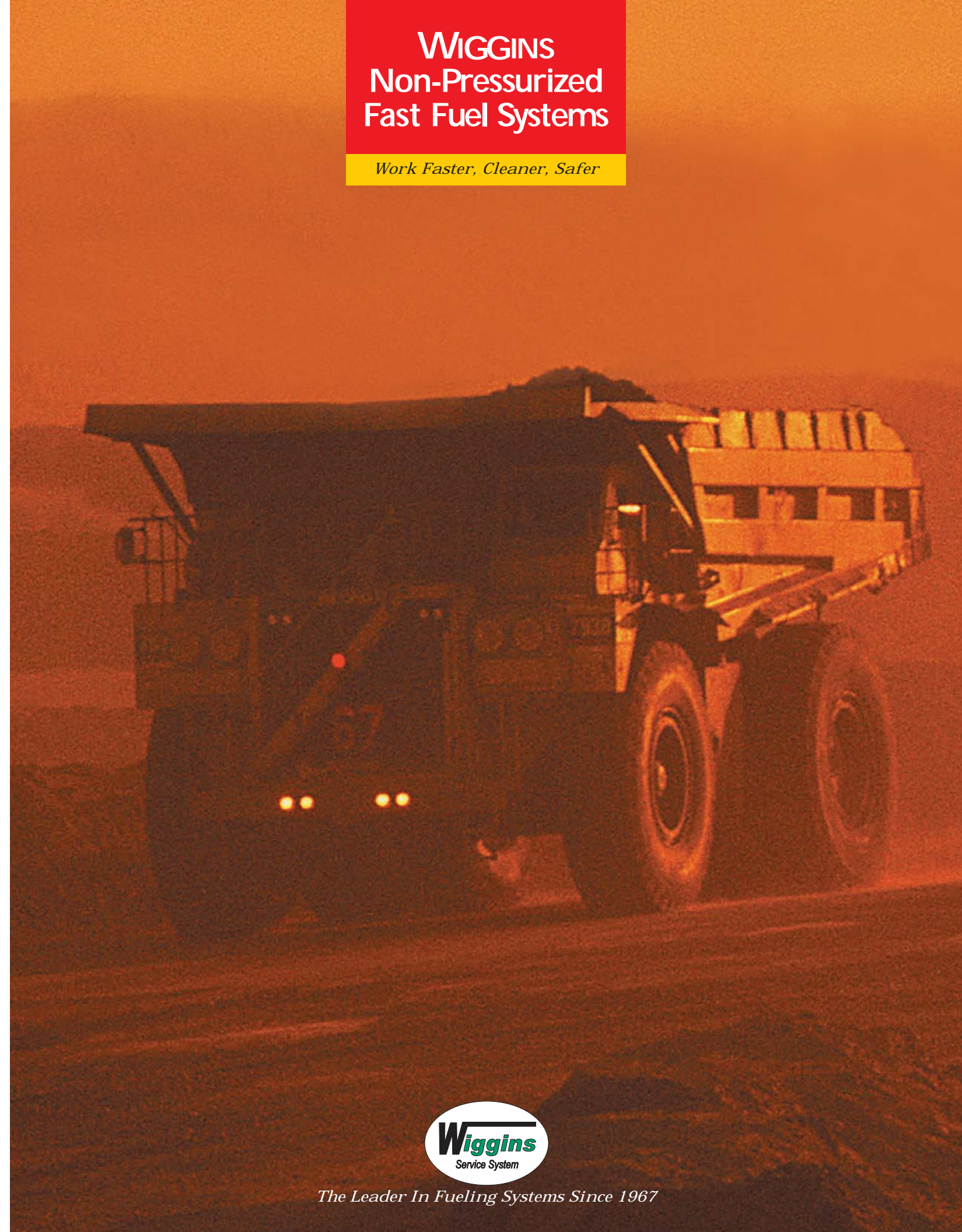

WIGGINS Non-Pressurized Fast Fuel Systems

Wiggins Service Systems
Work Faster, Cleaner, Safer

The JN125 – Fuel at 135 GPM

Wiggins Service Systems continues to lead the industry with innovative new products. We have recently introduced our second non-pressurized fast fuel system the JN125.

The JN125 allows you to use your existing Wiggins nozzle but does not pressurize the fuel tank.

Easy to Install

- Several mounting configurations to match vehicle installation
- Can be mounted on any type of fuel tank including plastic or thin wall tanks
- Wiggins retrofit installations are as easy as 1-2-3. No tank modification required:

1. Unscrew Wiggins receiver, screw in JN125 receiver
2. Unscrew Wiggins vent, screw in JV125 jet vent
3. Connect the two hoses between the receiver and jet vent
4. You are done in less than 30 minutes!

Flexible

- New applications are also easy to install. Multiple fittings and mounting configurations are available. Let Wiggins help you design a mounting configuration to fit your equipment

Fast

- Works with existing Wiggins fueling nozzles
- Delivers fuel up to 135 GPM
- Vehicles spend less time fueling and more time working

Clean

- No spill – Dry break coupling
- Designed for use in environmentally sensitive areas
- Overfill protection prevents fuel spills, reduces costs

Safe

- Most mounting configurations allow fueling to be completed while operator stands on the ground
- Reduces risk of worker injury due to slips and falls
- System is fully vented to atmosphere at all times – no pressure in tank



- Does not rely on failure – prone floats or valves; the Wiggins jet sensor has no moving parts increasing reliability

The VR300 – Fuel at 300 GPM

The VR300 system is also non-pressurized and has a flow capacity of up to 300 gallons per minute.

Non-pressurized systems allow operators to use Wiggins high flow fueling systems on vehicles with lightweight or composite fuel tanks.

Easy to Install

- Can be mounted directly on fuel tank, or in remote location
- Several manufacturers have equipped their vehicles to accept the VR300 mounting
- Options include air/fuel separator and vapor collection and return systems

Fast

- Designed for vehicles with large fuel tanks
- Fuel at rates up to 300 GPM
- Spend less time fueling and more time working

Clean

- Interlock feature prevents spills from disconnecting nozzle during fueling
- Positive shut off – cannot be overfilled, shut – off cannot be overridden
- Unique cam-lock nozzle attachment assures a leak – proof seal between nozzle and receiver.

Safe

- Uses same jet sensor technology as JN125
- Nozzle includes full tank indicator display
- Proven reliability – hundreds of units in use world wide

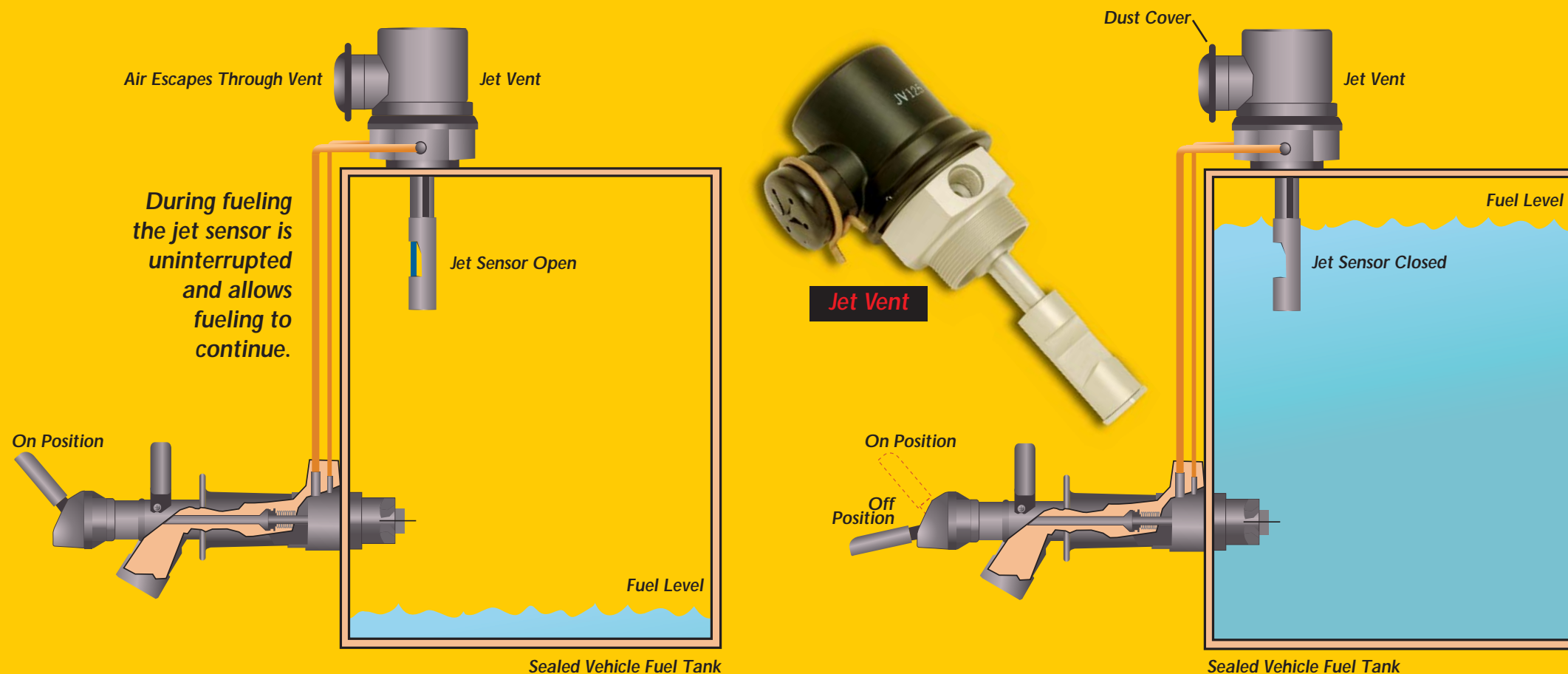

When the fuel level is higher than the jet sensor, the jet is interrupted and the system shuts off.